

IEEE Standard for Zinc-Coated Ferrous Lag Screws for Overhead Line Construction

IEEE Power Engineering Society

Sponsored by the
Transmission and Distribution Committee



Published by
The Institute of Electrical and Electronics Engineers, Inc.
3 Park Avenue, New York, NY 10016-5997, USA

6 November 2001

Print: SH94945
PDF: SS94945

IEEE Standard for Zinc-Coated Ferrous Lag Screws for Overhead Line Construction

Sponsor

**Transmission and Distribution Committee
of the
IEEE Power Engineering Society**

Approved 14 June 2001

IEEE-SA Standards Board

Abstract: Zinc-coated steel lag screws of the fetter drive, gimlet point, and twist drive types commonly used in overhead line construction are covered in this standard.

Keywords: Cold bend test, fetter drive, gimlet point, lag screws, twist drive, zinc-coated.

The Institute of Electrical and Electronics Engineers, Inc.
3 Park Avenue, New York, NY 10016-5997, USA

Copyright © 2001 by the Institute of Electrical and Electronics Engineers, Inc.
All rights reserved. Published 6 November 2001. Printed in the United States of America.

Print: ISBN 0-7381-2936-4 SH94945
PDF: ISBN 0-7381-2937-5 SS94945

No part of this publication may be reproduced in any form, in an electronic retrieval system or otherwise, without the prior written permission of the publisher.

IEEE Standards documents are developed within the IEEE Societies and the Standards Coordinating Committees of the IEEE Standards Association (IEEE-SA) Standards Board. The IEEE develops its standards through a consensus development process, approved by the American National Standards Institute, which brings together volunteers representing varied viewpoints and interests to achieve the final product. Volunteers are not necessarily members of the Institute and serve without compensation. While the IEEE administers the process and establishes rules to promote fairness in the consensus development process, the IEEE does not independently evaluate, test, or verify the accuracy of any of the information contained in its standards.

Use of an IEEE Standard is wholly voluntary. The IEEE disclaims liability for any personal injury, property or other damage, of any nature whatsoever, whether special, indirect, consequential, or compensatory, directly or indirectly resulting from the publication, use of, or reliance upon this, or any other IEEE Standard document.

The IEEE does not warrant or represent the accuracy or content of the material contained herein, and expressly disclaims any express or implied warranty, including any implied warranty of merchantability or fitness for a specific purpose, or that the use of the material contained herein is free from patent infringement. IEEE Standards documents are supplied “**AS IS.**”

The existence of an IEEE Standard does not imply that there are no other ways to produce, test, measure, purchase, market, or provide other goods and services related to the scope of the IEEE Standard. Furthermore, the viewpoint expressed at the time a standard is approved and issued is subject to change brought about through developments in the state of the art and comments received from users of the standard. Every IEEE Standard is subjected to review at least every five years for revision or reaffirmation. When a document is more than five years old and has not been reaffirmed, it is reasonable to conclude that its contents, although still of some value, do not wholly reflect the present state of the art. Users are cautioned to check to determine that they have the latest edition of any IEEE Standard.

In publishing and making this document available, the IEEE is not suggesting or rendering professional or other services for, or on behalf of, any person or entity. Nor is the IEEE undertaking to perform any duty owed by any other person or entity to another. Any person utilizing this, and any other IEEE Standards document, should rely upon the advice of a competent professional in determining the exercise of reasonable care in any given circumstances.

Interpretations: Occasionally questions may arise regarding the meaning of portions of standards as they relate to specific applications. When the need for interpretations is brought to the attention of IEEE, the Institute will initiate action to prepare appropriate responses. Since IEEE Standards represent a consensus of concerned interests, it is important to ensure that any interpretation has also received the concurrence of a balance of interests. For this reason, IEEE and the members of its societies and Standards Coordinating Committees are not able to provide an instant response to interpretation requests except in those cases where the matter has previously received formal consideration.

Comments for revision of IEEE Standards are welcome from any interested party, regardless of membership affiliation with IEEE. Suggestions for changes in documents should be in the form of a proposed change of text, together with appropriate supporting comments. Comments on standards and requests for interpretations should be addressed to:

Secretary, IEEE-SA Standards Board
445 Hoes Lane
P.O. Box 1331
Piscataway, NJ 08855-1331
USA

Note: Attention is called to the possibility that implementation of this standard may require use of subject matter covered by patent rights. By publication of this standard, no position is taken with respect to the existence or validity of any patent rights in connection therewith. The IEEE shall not be responsible for identifying patents for which a license may be required by an IEEE standard or for conducting inquiries into the legal validity or scope of those patents that are brought to its attention.

The IEEE and its designees are the sole entities that may authorize the use of the IEEE-owned certification marks and/or trademarks to indicate compliance with the materials set forth herein.

Authorization to photocopy portions of any individual standard for internal or personal use is granted by the Institute of Electrical and Electronics Engineers, Inc., provided that the appropriate fee is paid to Copyright Clearance Center. To arrange for payment of licensing fee, please contact Copyright Clearance Center, Customer Service, 222 Rosewood Drive, Danvers, MA 01923 USA; (978) 750-8400. Permission to photocopy portions of any individual standard for educational classroom use can also be obtained through the Copyright Clearance Center.

Introduction

(This introduction is not part of IEEE Std C135.3-2001, IEEE Standard for Zinc-Coated Ferrous Lag Screws for Overhead Line Construction.)

This standard covers requirements for various types of zinc-coated steel lag screws for overhead line construction.

Participants

At the time this standard was completed, the Working Group on Pole Line Hardware of the Transmission and Distribution Committee of the IEEE Power Engineering Society had the following membership:

Ronald J. Oedemann, *Chair*

Chris Severs, *Vice-Chair*

Nick Annas
James D. Applequist
Frederick W. Burtelson
Edward Dziedzic
Thomas Evison
John Farrington
Donald G. Heald

Richard W. Hensel
Nunnally Johnson
Ralph O. Jones
Edward A. Kiernozek
Robert O. Kluge
David J. Koury
Keith E. Lindsey

Robert C. Peters
Patrick D. Quinn
Karl F. Reed II
Steven D. Scholfield
Stephen F. Smith
Lewis M. Whisonant
Cary H. Yuan

The following members of the balloting committee voted on this standard:

Richard Aichinger
James D. Applequist
Anthony C. Baker
R. Allen Bernstorf
Nelson G. Bingel
Frederick W. Burtelson
Glenn A. Davidson
Frank A. Denbrock
Nicholas J. DeSantis
Guru Dutt Dhingra

John Farrington
Randall C. Groves
Richard W. Hensel
Magdi F. Ishac
Ralph O. Jones
Robert O. Kluge
Daleep C. Mohla
Yakov Motlis
Ronald J. Oedemann

Mark Ostendorp
Robert G. Oswald
Roger Pandanda
Robert C. Peters
Patrick D. Quinn
Donald Sandell
Neil P. Schmidt
Chris Severs
Mohamed H. Shwehdi
Stephen F. Smith

When the IEEE-SA Standards Board approved this standard on 14 June 2001, it had the following membership:

Donald N. Heirman, *Chair*

James T. Carlo, *Vice Chair*

Judith Gorman, *Secretary*

Satish K. Aggarwal
Mark D. Bowman
Gary R. Engmann
Harold E. Epstein
H. Landis Floyd
Jay Forster*
Howard M. Frazier
Ruben D. Garzon

James H. Gurney
Richard J. Holleman
Lowell G. Johnson
Robert J. Kennelly
Joseph L. Koepfinger*
Peter H. Lips
L. Bruce McClung
Daleep C. Mohla

James W. Moore
Robert F. Munzner
Ronald C. Petersen
Gerald H. Peterson
John B. Posey
Gary S. Robinson
Akio Tojo
Donald W. Zipse

*Member Emeritus

Also included is the following nonvoting IEEE-SA Standards Board liaison:

Alan Cookson, *NIST Representative*
Donald R. Volzka, *TAB Representative*

Andrew D. Ickowicz
IEEE Standards Project Editor

Contents

1.	Overview.....	1
	1.1 Scope.....	1
	1.2 Application.....	1
2.	References.....	1
3.	Material.....	2
	3.1 Bolts.....	2
4.	Dimensions.....	2
5.	Strength.....	2
	5.1 Cold bend test.....	2
6.	Corrosion protection.....	3
7.	Sizes and types.....	3
8.	Finish.....	3
9.	Marking.....	3
10.	Marking of shipping packages.....	3

IEEE Standard for Zinc-Coated Ferrous Lag Screws for Overhead Line Construction

1. Overview

1.1 Scope

This standard covers zinc-coated steel lag screws of the fether drive, gimlet point, and twist drive types commonly used in overhead line construction.

1.2 Application

The lag screws conforming to this standard shall, in all respects, meet the basic dimensional and performance requirements hereinafter stated. The text, specifications or standards references, and associated Figure 1 through Figure 5 supplement each other and shall be considered as parts of this standard.

Metric lag screws are not covered by this standard.

2. References

The following standards shall be used in conjunction with this standard. When the following standards are superseded by an approved revision, the revision shall apply.

ANSI B18.2.1-1992, American National Standard for Square and Hex Bolts and Screws¹

ASTM A153/A153M-95, Standard Specification for Zinc-Coating on Iron and Steel Hardware²

¹ANSI publications are available from the Sales Department, American National Standards Institute, 11 West 42nd Street, 13th Floor, New York, NY 10036, USA (<http://www.ansi.org/>).

²ASTM publications are available from the American Society for Testing and Materials, 100 Barr Harbor Drive, West Conshohocken, PA 19428-2959, USA (<http://www.astm.org/>).

3. Material

3.1 Bolts

All lag screws shall be made from one of the following materials:

- a) Hot-headed lag screws shall be made from hot-rolled steel which has been produced by the open hearth, basic-oxygen, or electric-furnace process and which is of a grade and quality suitable to meet the requirements of this standard.
- b) Cold-headed lag screws shall be made from steel cold-heading wire which has been produced by the open hearth, basic-oxygen, or electric-furnace process and which is of a grade and quality suitable to meet the requirements of this standard, and shall be reheated (stress relieved) if necessary to meet the requirements of this standard.

4. Dimensions

All dimensions are in inches prior to zinc coating.

All lag screws shall be square or hex and in accordance with ANSI B18.2.1-1992³, as specified in Figure 3 and Figure 4.

Lag screw threads shall be machine-rolled or cut as specified in the data sheets.

5. Strength

Lag-screw heads shall be of sufficient strength to develop the body tensile strength of the screws. Failure shall occur in the shank or threaded section and not at the junction of the head and shank. In no case shall the strength be less than the following:

Normal diameter of screw (inches)	Minimum strength (pounds)
1/4	1500
5/16	2300
3/8	3500
1/2	6500

5.1 Cold bend test

After removal of the threads to the root diameter, the unthreaded portion of bolts shall be capable of being bent while at room temperature (50 °C to 90 °C) at any point through an angle of 180°, about a diameter equal to the diameter of the bolt without cracking the steel on the outside of the bent portion.

³Information on references can be found in Clause 2.

6. Corrosion protection

Lag screws shall be zinc-coated. The coating shall be applied by:

- a) The hot-dip process in accordance with ASTM A153/A153M-95, or
- b) Another method producing a zinc coating that meets the requirements of ASTM A153/A153M-95 for adhesion, purity, and thickness applicable to the class of material being coated.

7. Sizes and types

The sizes and types shall be as specified on the data sheets.

8. Finish

All lag screws shall be free from badly formed or otherwise defective heads and bodies.

9. Marking

Lag screws shall bear the manufacturer's symbol or identification mark.

10. Marking of shipping packages

Each package shall be marked with the vendor's name and catalog number.

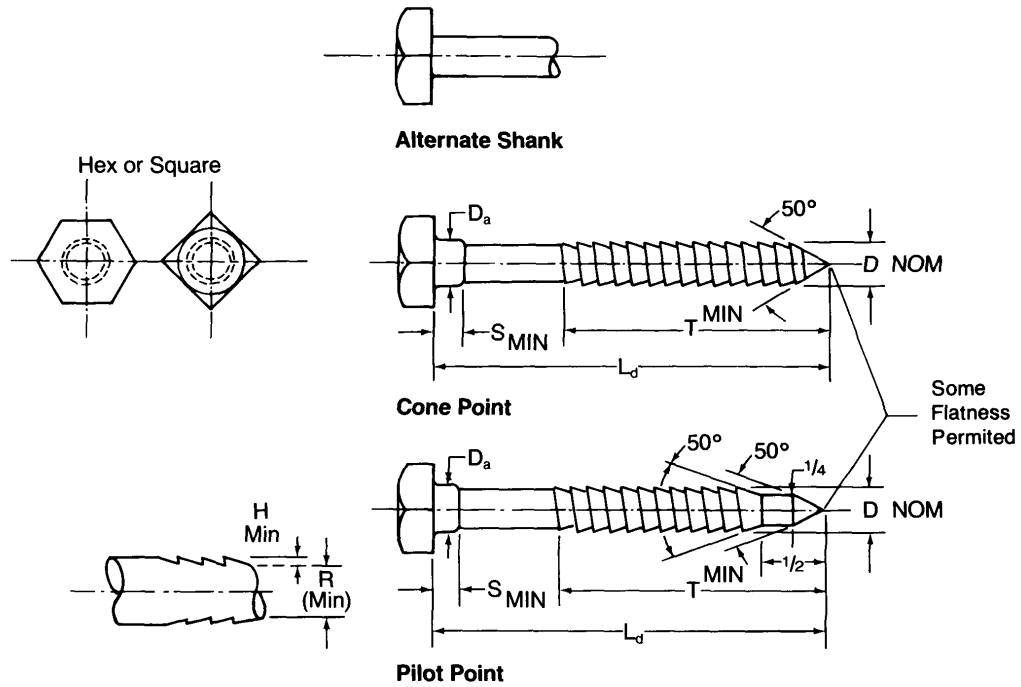

BODY DIMENSIONS				THREADS PER INCH	RA	HB
D	L	T	S		ROOT DIA.	DEPTH OF THREAD
DIA. OF SCREW	LENGTH	MIN. THREAD	SHOULDER			
1/4	2 1/2	1 3/4	.094	10	.18	.01
3/8	2 1/2	1 3/4	.125	8 or 9	.30	.02
	3	2				
1/2	4	2 1/2	.156	6 or 7	.41	.02
	4 1/2	2 3/4				

All Dimensions In Inches

**FETTER DRIVE LAG SCREW
ROLLED THREAD**

a: 1/64 d: 1/8 g: 3/8 k: 1
 b: 1/32 e: 3/16 h: 1/2 x: 0
 c: 1/16 f: 1/4 j: 3/4

ALLOWABLE VARIATIONS
 SINGLE LETTER INDICATES, SAME + or -, a: ± 1/64
 TWO LETTERS INDICATE, FIRST + SECOND -, ax: + 1/64 - 0

Figure 1—Dimensions for fetter drive lag screws

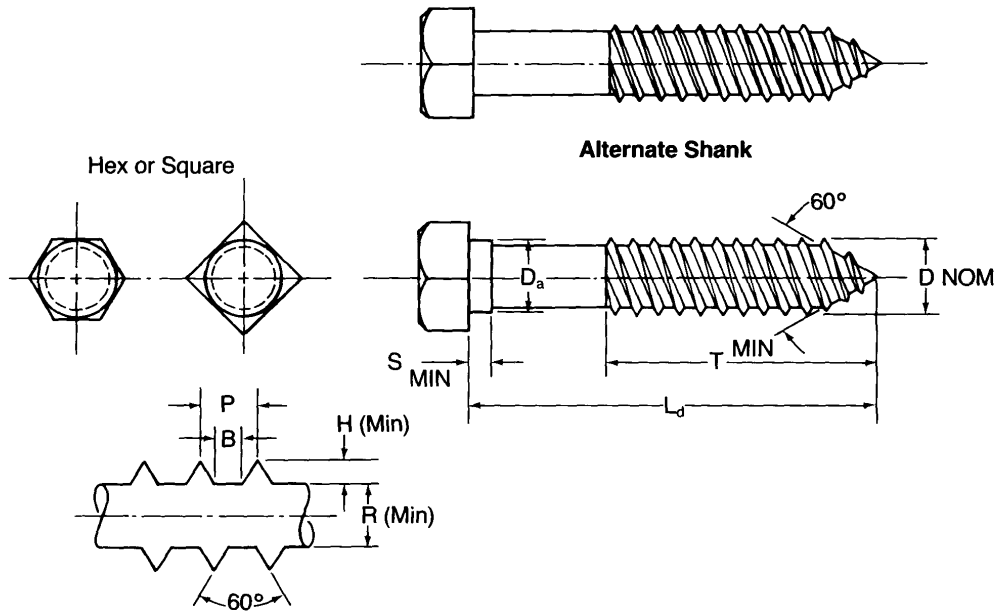

D	L	T	P	B	H	R	S	THREADS PER INCH
DIA. OF SCREW	LENGTH	MIN. THREAD LENGTH	THREADS DIMENSIONS			SHOULDER		
			PITCH	FLAT AT ROOT	DEPTH OF THREAD		ROOT DIA.	
¼	2	1½	.100	.043	.02	.16	.094	10
	2½	1¾						
	3	2						
5/16	2½	1¾	.111	.048	.02	.21	.125	9
	3	2						

All Dimensions in Inches

**GIMLET POINT LAG SCREW
ROLLED OR CUT THREAD**

a: 1/64 d: 1/8 g: 3/8 k: 1
 b: 1/32 e: 3/16 h: 1/2 x: 0
 c: 1/16 f: 1/4 j: 3/4

ALLOWABLE VARIATIONS
 SINGLE LETTER INDICATES, SAME + or -, a: ± 1/64
 TWO LETTERS INDICATE, FIRST + SECOND -, ax: + 1/64 - 0

Figure 2—Dimensions for gimlet point lag screws

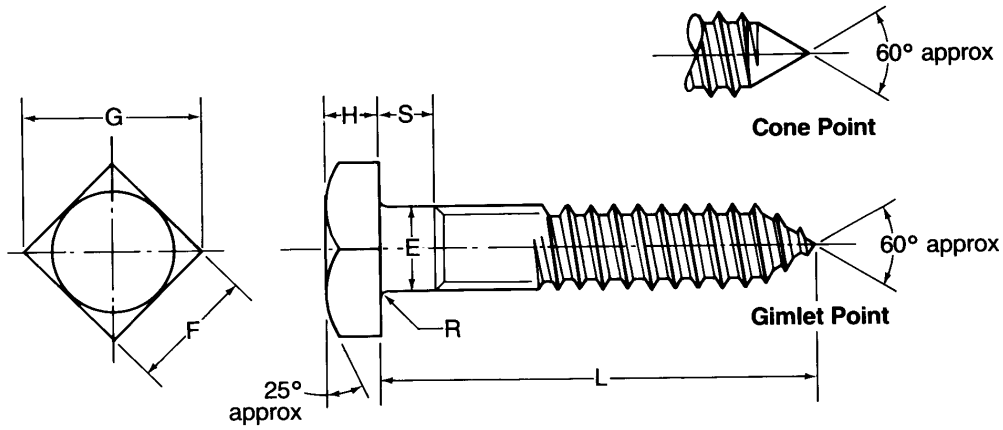

Nominal Size or Basic Product Dia (12)	E		F			G		H			S	R		
	Body or Shoulder Dia (6), (7)		Width Across Flats (3)			Width Across Corners		Height			Shoulder Length (7)	Radius of Fillet		
	Max	Min	Basic	Max	Min	Max	Min	Basic	Max	Min	Min	Max	Min	
No. 10	0.1900	0.199	0.178	9/32	0.281	0.271	0.398	0.372	1/8	0.140	0.110	0.094	0.03	0.01
1/4	0.2500	0.260	0.237	3/8	0.375	0.362	0.530	0.498	11/64	0.188	0.156	0.094	0.03	0.01
5/16	0.3125	0.324	0.298	1/2	0.500	0.484	0.707	0.665	13/64	0.220	0.186	0.125	0.03	0.01
3/8	0.3750	0.388	0.360	9/16	0.562	0.544	0.795	0.747	1/4	0.268	0.232	0.125	0.03	0.01
7/16	0.4375	0.452	0.421	5/8	0.625	0.603	0.884	0.828	19/64	0.316	0.278	0.156	0.03	0.01
1/2	0.5000	0.515	0.482	3/4	0.750	0.725	1.061	0.995	21/64	0.348	0.308	0.156	0.03	0.01
5/8	0.6250	0.642	0.605	1-5/16	0.938	0.906	1.326	1.244	27/64	0.444	0.400	0.312	0.06	0.02
3/4	0.7500	0.768	0.729	1-1/8	1.125	1.088	1.591	1.494	1/2	0.524	0.476	0.375	0.06	0.02
7/8	0.8750	0.895	0.852	1-5/16	1.312	1.269	1.856	1.742	19/32	0.620	0.568	0.375	0.06	0.02
1	1.0000	1.022	0.976	1-1/2	1.500	1.450	2.121	1.991	21/32	0.684	0.628	0.625	0.09	0.03
1 1/8	1.1250	1.149	1.098	1-11/16	1.688	1.631	2.386	2.239	3/4	0.780	0.720	0.625	0.09	0.03
1 1/4	1.2500	1.277	1.223	1-7/8	1.875	1.812	2.652	2.489	27/32	0.876	0.812	0.625	0.09	0.03

Figure 3—Dimensions of square lag screws

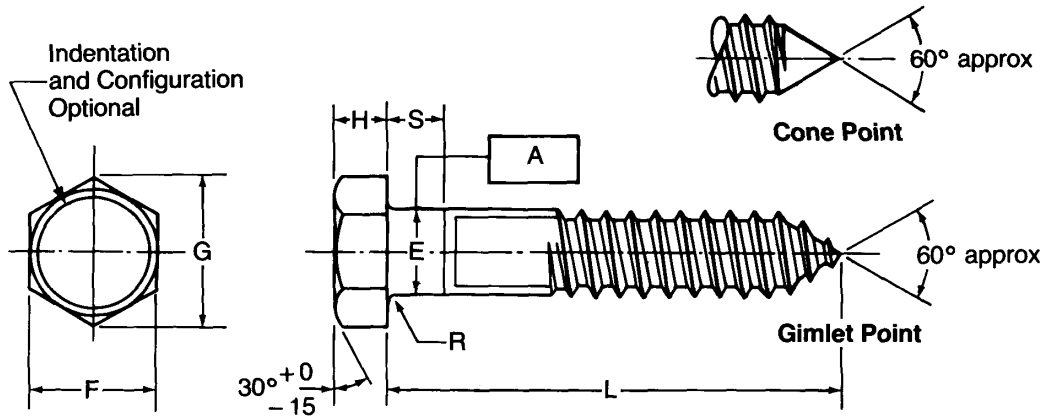

Nominal Size or Basic Product Dia (12)	E		F			G		H			S	R		
	Body or Shoulder Dia (6), (7)		Width Across Flats (3)			Width Across Corners		Height			Shoulder Length (7)	Radius of Fillet		
	Max	Min	Basic	Max	Min	Max	Min	Basic	Max	Min	Min	Max	Min	
No. 10	0.1900	0.199	0.178	9/32	0.281	0.271	0.323	0.309	1/8	0.140	0.110	0.094	0.03	0.01
1/4	0.2500	0.260	0.237	7/16	0.438	0.425	0.505	0.484	11/64	0.188	0.150	0.094	0.03	0.01
5/16	0.3125	0.324	0.298	1/2	0.500	0.484	0.577	0.552	7/32	0.235	0.195	0.125	0.03	0.01
3/8	0.3750	0.388	0.360	9/16	0.562	0.544	0.650	0.620	1/4	0.268	0.226	0.125	0.03	0.01
7/16	0.4375	0.452	0.421	5/8	0.625	0.603	0.722	0.687	19/64	0.316	0.272	0.156	0.03	0.01
1/2	0.5000	0.515	0.482	3/4	0.750	0.725	0.866	0.826	11/32	0.364	0.302	0.156	0.03	0.01
5/8	0.6250	0.642	0.605	1-5/16	0.938	0.906	1.083	1.033	27/64	0.444	0.378	0.312	0.06	0.02
3/4	0.7500	0.768	0.729	1-1/8	1.125	1.088	1.299	1.240	1/2	0.524	0.455	0.375	0.06	0.02
7/8	0.8750	0.895	0.852	1-5/16	1.312	1.269	1.516	1.447	37/64	0.604	0.531	0.375	0.06	0.02
1	1.0000	1.022	0.976	1-1/2	1.500	1.450	1.732	1.653	43/64	0.700	0.591	0.625	0.09	0.03
1-1/8	1.1250	1.149	1.098	1-11/16	1.688	1.631	1.949	1.859	3/4	0.780	0.658	0.625	0.09	0.03
1-1/4	1.2500	1.277	1.223	1-7/8	1.875	1.812	2.165	2.066	27/32	0.876	0.749	0.625	0.09	0.03

Figure 4—Dimensions of hex lag screws

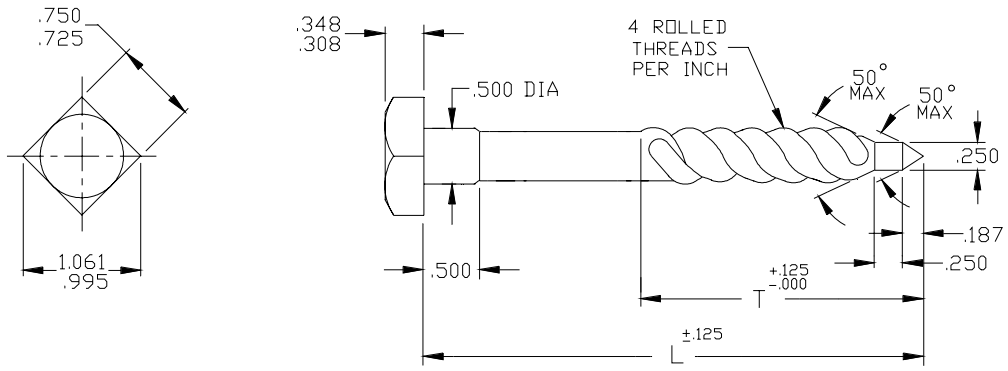

L	T
3.000	2.250
4.000	2.625
4.500	2.625
5.000	3.000

NOTES:

1. UNSPECIFIED DIMENSIONAL TOLERANCES ± 0.031
2. UNSPECIFIED ANGULAR TOLERANCES $\pm 2^\circ$
3. ALL DIMENSIONS ARE IN INCHES EXCEPT AS SPECIFIED

Figure 5—Dimensions for twist drive lag screws